

Ryton®



**SOLVAY**

asking more from chemistry®

# Ryton® PPS

Design Guide

**SPECIALTY  
POLYMERS**



# Table of Contents

<b>Introduction</b> .....	<b>5</b>	<b>Assembly Methods</b> .....	<b>16</b>
<b>Compound Selection</b> .....	<b>5</b>	Ultrasonic Welding .....	16
The Fiberglass Reinforced Series .....	5	Ultrasonic Staking .....	17
The Fiberglass and Mineral Reinforced Series .....	5	Heat Staking .....	17
<b>Part Design</b> .....	<b>6</b>	Snap Fit .....	17
Wall Thickness .....	6	Rivet Assembly .....	18
Weld Lines .....	6	Adhesives .....	18
Fiberglass Orientation .....	7	Tapped Threads for Bolts .....	18
Variable Wall Thickness .....	7	Self-Tapping Screws .....	19
Radii .....	7	Screw Data .....	20
Ribs and Bosses .....	8	Ultrasonic Inserts .....	21
Drafts and Undercuts .....	8	Molded-In Threads .....	21
Typical Tolerances .....	8	Molded-In Inserts .....	22
<b>Mold Design</b> .....	<b>9</b>	Interference Fit .....	22
Mold Temperature .....	9	Machining .....	22
Shrinkage .....	9	<b>Computer Aided Engineering (CAE)</b> .....	<b>22</b>
Tool Steels .....	10	<b>Conclusion</b> .....	<b>22</b>
Coating Methods .....	10		
Surface Treatments .....	10		
Sprue Design .....	11		
Runner Design .....	11		
Venting .....	12		
Gate Geometries .....	12		
Gates .....	13		
Center/sprue gate .....	13		
Pin gate .....	13		
Fan gate .....	13		
Diaphragm (disk) gate .....	13		
Spoke gate .....	13		
Flash gate .....	13		
Edge gate .....	13		
Tunnel (submarine) gate .....	13		
Coring .....	15		
Draft .....	15		



## Compound Selection

There are two basic series of Ryton® PPS compounds from which to select.

### The Fiberglass Reinforced Series

This series includes Ryton® R-4, R-4-200, R-4-220 and R-4-230. The most common determining factors for selection between these compounds are flow length, mechanical strength and hot water resistance.

Typical glass-filled PPS applications include electronic connectors, under-hood automotive components, high heat appliance parts and a wide variety of industrial products.

### The Fiberglass and Mineral Reinforced Series

This series includes Ryton® R-7, R-7-120, R10-110 and BR111. In addition to the 260°C (500°F) Heat Deflection Temperature (HDT) at 1.8 MPa (264 psi) and excellent mechanical strength, these compounds provide enhanced electrical properties. This feature allows glass and mineral filled Ryton® PPS compounds to be used in a wide range of applications including electronic devices, switches, and high density interconnection devices.

Please refer to [www.solvayspecialtypolymers.com](http://www.solvayspecialtypolymers.com) for specific mechanical, physical, electrical, chemical, and thermal data for all Ryton® PPS compounds.

# Part Design

Part design is a critical aspect of any successful application. Matching end-use requirements of the part with a material's capabilities is the first step. The designer must take into consideration the strength of the part utilizing proper wall thickness and fiber orientation, and also consider the ability to fill the required mold. A well-designed part will incorporate uniform wall thickness, adequate corner radii, ample draft, sufficient venting, and a gate location that minimizes the effects of weld lines.

Incorporating proper design elements will result in a part that can be economically manufactured and reproducible to very tight molding tolerances.

## Wall Thickness

Material cost and cycle time are directly related to wall thickness. Optimum part design balances minimum wall thickness versus sufficient strength. The minimum wall section must be thick enough for the material to fill the mold under typical processing conditions. With Ryton® PPS, as with all resins, it is important to strive for uniform wall thickness. When this is impractical, parts should be designed to fill from thick to thin areas. Uniform wall thickness is also desirable to minimize internal stresses. Where wall thickness must vary, it should differ by no more than 40 % of the thickest wall. Likewise, intersections should have a radius of 60 % of the thinner wall.

Wall thickness variations can affect the direction of material flow and therefore shrinkage. Due to the fiberglass and molecular orientation, transverse shrinkage is roughly double the flow direction shrinkage. For this reason, it is important that the wall thickness be symmetrical through the cross section of the part. If thick sections are required to fill the part, the cross section should be as symmetrical as possible.

Many Ryton® PPS part applications have wall thicknesses as thin as 0.38–0.51 mm (0.015–0.020 inch). For example, one battery pack cover measures 25.4 mm × 12.7 mm with 0.38 mm walls (1 × 0.500 × 0.015 inch). There are various connectors having 0.45 mm (0.018 inch) walls, and some very small parts have walls as thin as 0.15 mm (0.006 inch).

In very thick sections, the surface stops shrinking as it solidifies while the interior bulk continues cooling and shrinking. The difference in shrinkage can pull the material apart leaving sink marks and shrink voids which reduce overall strength. Maximum allowable wall thickness depends on the Ryton® PPS compound selected. Most Ryton® PPS parts should not have wall thickness greater than 9.52 mm (0.375 inch).

Wall sections must be thick enough to allow adequate material flow into the tool. Figures 1 and 2 illustrate the effect of wall thickness and stock temperature on spiral flow of Ryton® PPS. Since spiral flow is not packed at the end, only 75 % of this length should be used for design purposes.

**Figure 1:** Spiral flow vs. wall thickness at 316 °C (600 °F), maximum injection rate and 2 second fill

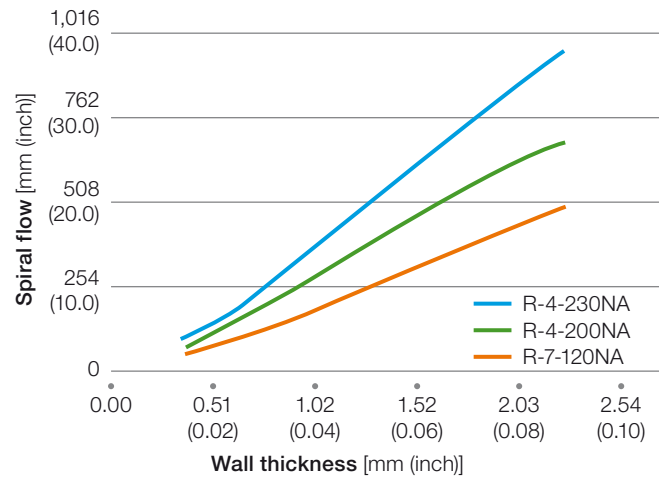

**Figure 2:** Spiral flow vs. stock temperature at 2.23 mm (0.090 inch) thickness with 2 second fill

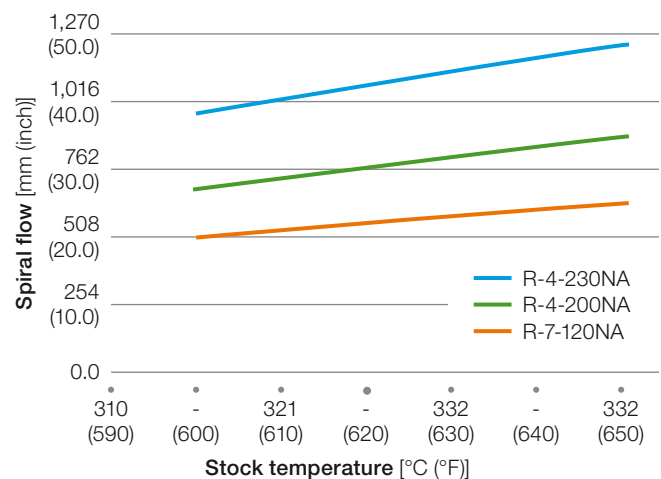

## Weld Lines

Weld lines are formed when the melt front divides and then flows back together. Typically the weld line interface is resin rich since glass fiber does not cross the interface. This results in lower mechanical strength. If possible, the weld line should be eliminated or located in an area with lower load requirements. Gate location is critical in determining weld line location. If weld lines must bear stress, the part design should compensate for typical strengths indicated in Figure 3. Weld line strength depends heavily on processing, so the part and tool design should allow for rapid injection, thorough packing and adequate venting at the weld.

**Figure 3:** Weld line strength for Ryton® PPS compounds

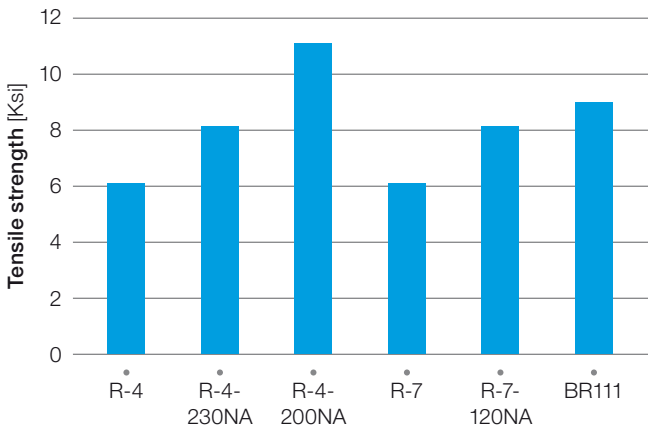

### Fiberglass Orientation

The orientation of the fiberglass reinforcement affects strength. Ryton® PPS is stronger in the direction of flow as compared to the transverse direction. Fiberglass orientation should be utilized to enhance the strength requirements of the part. Part design and gate location should minimize stress in the transverse direction. In some cases, wall thickness must be increased to compensate for lower transverse strength. Refer to Figure 4 for transverse versus flow direction strength information.

**Figure 4:** Tensile strength vs. fiberglass orientation

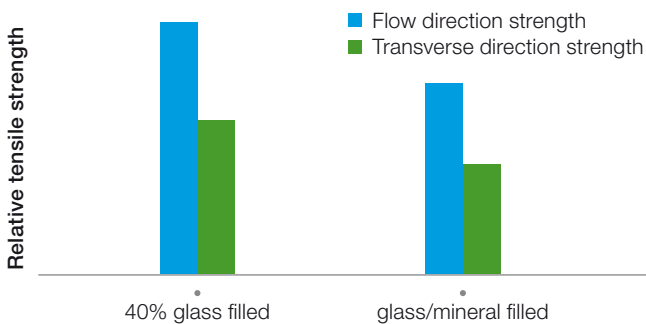

### Variable Wall Thickness

Some areas of a part may require more strength than others. However, wall thickness should be as uniform as possible throughout the part. Radical variations in wall thickness tend to concentrate stresses – both molded-in and externally applied. The shrinkage differential between thick and thin sections causes molded-in stress at the juncture. A uniform wall section creates an even flow that has uniform shrinkage and minimal molded-in stress.

If wall thickness changes are unavoidable, they should be gradual in order to minimize stress concentration. Figure 5 shows an example of the preferred method for achieving a variable wall thickness. Coring the part in thick sections is a good way to ensure uniform wall thickness. Coring will also provide a means for cost savings in material usage. For further information on coring refer to the Mold Design section.

**Figure 5:** Wall thickness transitions

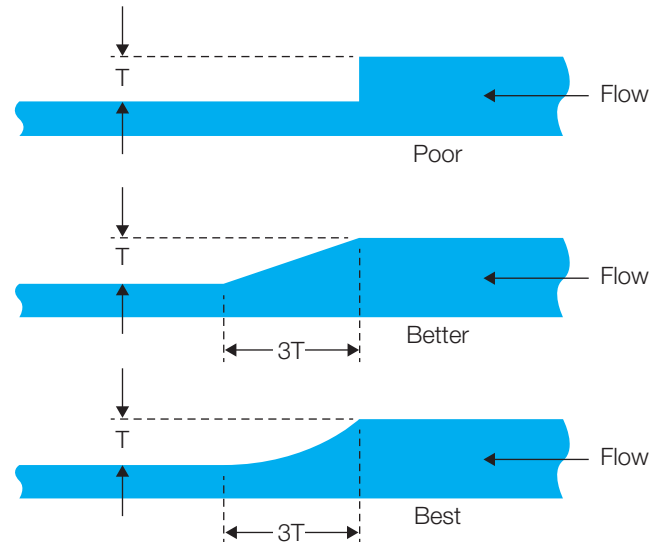

### Radii

Ryton® PPS compounds, as is the case with other engineering thermoplastics, are notch sensitive. Therefore sharp corners should be avoided in part designs. The optimum fillet radius for Ryton® PPS compounds is  $0.6T$ , where  $T$  represents the wall (Figure 6) thickness.

**Figure 6:** Design for radii

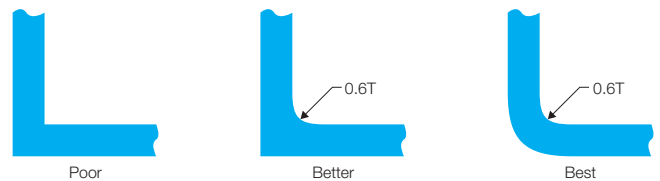

Abrupt changes in part geometry, like sharp inside corners, cause amplification of stress in the area of the abrupt change. Quick geometry variations can promote additional problems as well such as flow impedance, molded-in stress and voids. Figure 7 shows the relationship of stress concentration at a sharp corner as a function of the radius to wall thickness ratio.

**Figure 7:** Typical stress concentration factor

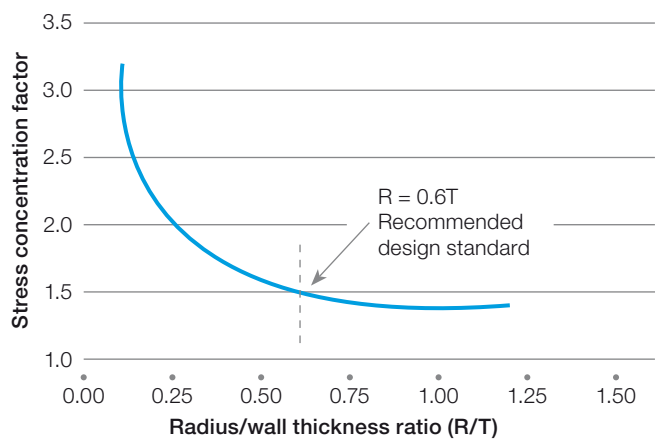

## Ribs and Bosses

Proper rib design can increase part strength significantly. Ribs are most effective in a thin area that must bear a load perpendicular to its plane. Figure 8 illustrates the optimum relationship between wall thickness, rib thickness and radius.

In addition to allowing reduced wall thickness and cooling time, ribbing can improve flow paths to make the part easier to fill. However, ribs that are too thick can cause sink marks, warpage and cracking. The part design must incorporate a sufficient radius at the base of the rib.

Boss design should follow the same rules: avoid thick sections and provide sufficient radius at the base. Figure 9 shows the recommended boss design for Ryton® PPS parts.

**Figure 8:** Recommended rib design

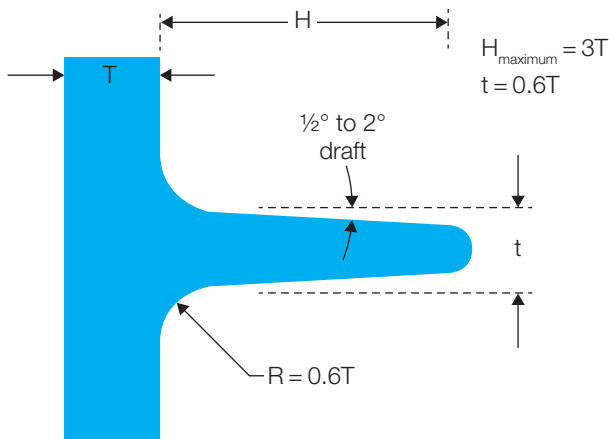

**Figure 9:** Recommended boss design

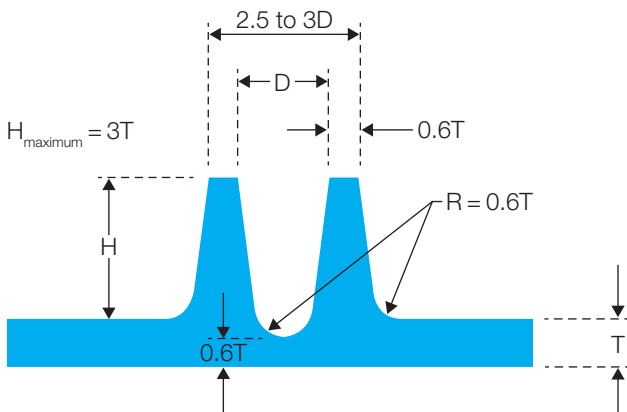

## Drafts and Undercuts

Ryton® PPS compounds replicate mold surfaces very well and flex little during ejection. Therefore, the part design should avoid undercuts and provide sufficient draft to eject the part without flexure. Short cores and shallow cavities of 4.76 mm (3/16 inch) or less should have at least  $1/4^\circ$  draft per side. As cavity depth and core length increase to one or two inches, the draft angle should increase up to  $2^\circ$  per side. Polishing the core and cavity will improve release so a surface finish of 0.0001 mm (4 microinch) or better should be specified. Polish marks should parallel the direction of part ejection.

In special cases, an undercut can be useful to retain parts on the core or cavity during mold opening. The interference should range from 0.0127–0.0254 mm (0.0005–0.001 inch). Since Ryton® PPS compounds are very stiff, any undercut areas in a mold will experience high wear rates.

## Typical Tolerances

Typically, Ryton® PPS exhibits very low shrinkage. Therefore, molded part tolerances are highly reproducible, but depend on the dimension. The larger the dimension, the larger the tolerance needed. Generally for small to medium sized parts a tolerance of 0.1% of a given dimension can be held. Larger parts require tolerances as high as 0.2%. For an optimally gated small part, tolerances as tight as 0.01% can be achieved.



Mold design is as critical as part design. The best mold designs optimize the performance properties of Ryton® PPS. For example, to produce crystalline parts, the mold must be designed to operate at 135 °C (275 °F) or hotter. It must compensate for material shrinkage within the required level of dimensional precision. A well designed mold will control the effects of gate location and melt flow paths on shrinkage, warpage, and part strength. The tool steel used is also a consideration since it will determine the length of time the mold will be in service.

## Mold Temperature

Mold temperature significantly affects crystallinity and thus the dimensional stability of the part when it is exposed to temperatures above the glass transition ( $T_g$ ) (Figure 10) temperature.

**Figure 10:** Effect of mold temperature on crystallinity

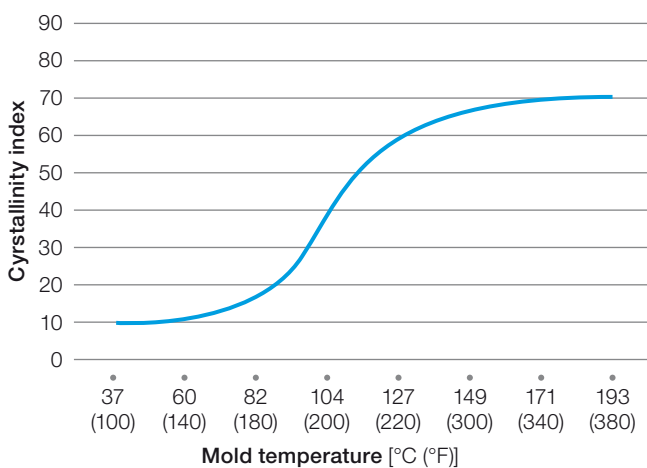

**NOTE:** It is very important to keep the mold temperature either above 135 °C (275 °F) or below 82 °C (180 °F). To operate between these temperatures will produce varying resultant dimensions. Parts that are used at high temperatures should be molded using a mold temperature at or above 135 °C (275 °F).

Please refer to the Ryton® PPS Processing Guide for specific information regarding mold heating/cooling equipment and their manufacturers.

## Shrinkage

Shrinkage is affected by part weight and thickness, compound type, fiber orientation, mold temperature, amount of coring in the mold and any post-molding annealing. Figure 11 shows the expected shrinkage for a highly cored part.

**Figure 11:** Flow and transverse shrinkage for highly cored parts

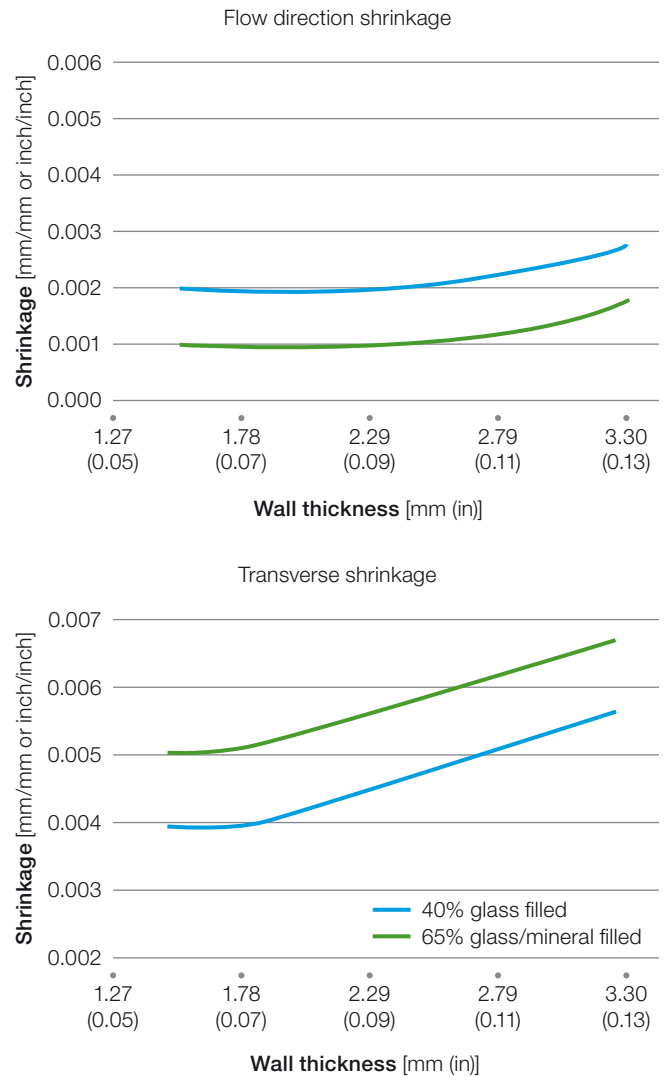

For any given part, mold shrinkage decreases with increasing part weight, as fully packing out the part decreases shrinkage. Thicker wall sections generally exhibit higher shrinkage than thinner ones since they hold heat longer. Mold shrinkage increases somewhat with increasing mold temperature due to increased crystallization. Parts restrained during molding by coring will exhibit lower shrinkage than unrestrained parts. Annealing also affects shrinkage in Ryton® PPS parts. Cold-molded parts will develop substantial crystallinity and shrink considerably if held above 204 °C (400 °F) for extended periods.

Conversely, hot-molded parts already have a high level of crystallinity and exposure to temperatures above 204 °C (400 °F) result in very little additional shrinkage.

### Tool Steels

Because of the abrasive nature of the glass and mineral fillers used in Ryton® PPS compounds, hard tool steels are required. For long run production molds, A-2, D-2 or D-7 tool steels hardened to Rockwell C-60+ is recommended. Of these, A-2 is commonly used since it is a little more flexible and forgiving. Many times cavity blocks of these harder tool steels can be inserted into a mold base of softer steel to minimize cost and make machining easier. Because especially high rates of wear are typically encountered at gates, removable (replaceable) gate blocks of D-2 steel are often used. For low volume runs, S-7 and H-13 are acceptable softer steels. For complex electrical connector molds, S7 is a good choice for core pins to minimize breakage because of the increased ductility. Coatings and surface treatments are two methods for achieving higher wear resistance in long run production molds built from softer tool steels.

### Coating Methods

Recommended mold coating methods are slow deposition Dense Chrome and Electroless Nickel. These coatings provide good mold release characteristics and fairly long life. It is important to note that steels with a surface finish of 0.0001 mm (4 microinches) or better experience extended service life.

### Surface Treatments

Successfully used surface treatments are:

- Borofuse®
- LSR-1®
- Nitride®
- Diamond Black®

Please consult trade publications such as the “Thomas Register for Metal Treating Companies.” Figures 12 and 13 show tool wear of different steels and surface treatments.

**Figure 12:** Wear resistance of tool steels

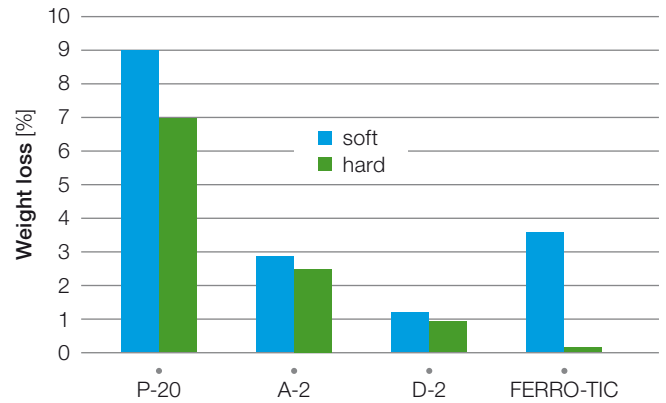

**Figure 13:** Wear resistance of surface treatments

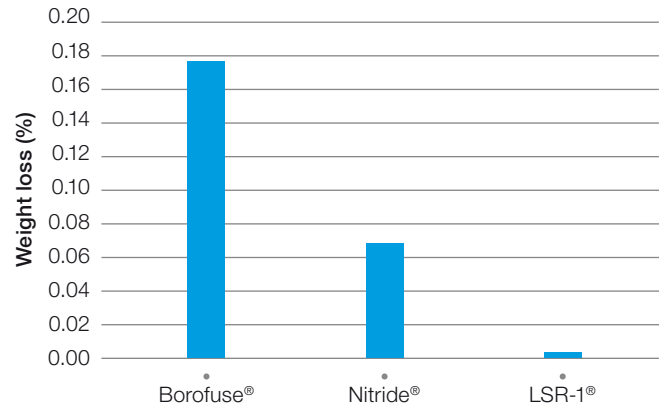

Prototype tooling is often an excellent way to produce a short production run of parts and discover the unique facets of producing particular parts. Prototype tools can be made from a variety of softer steels and aluminum. The ease of machining the softer metals makes them economical to use during prototyping. Care must be taken, however, with aluminum tools since they are more difficult to heat uniformly and cannot withstand high injection and clamping pressure as well as steel tools.

## Sprue Design

Standard sprue designs are quite acceptable with nominal values of 2° of draft and reverse taper or Z-cut sprue puller systems. Keep the runner as short and highly polished as possible to ease part removal from the stationary half of the mold. Figure 14 shows a standard sprue design.

**Figure 14:** Standard sprue design

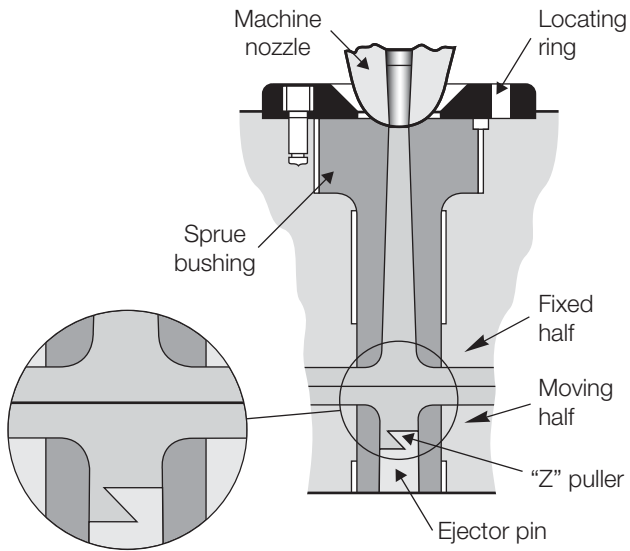

## Runner Design

It is very important that the runner system be designed so that the mold cavities fill uniformly and in a balanced fashion.

Runners of many types can be used successfully with Ryton® PPS compounds. Full round and trapezoidal runners are preferred (Figure 15). Runners should be designed with cold slug wells.

**Figure 15:** Trapezoidal runner profiles

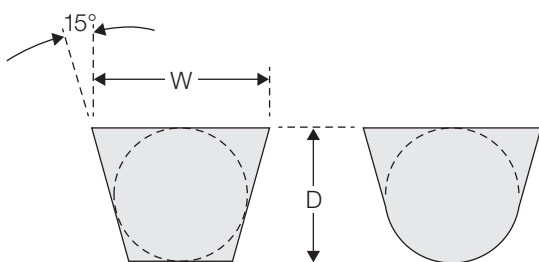

Equivalent runner diameter "D"

Width [W]		Depth [D]	
mm	inch	mm	inch
6.4	1/4	4.8	3/16
7.9	5/16	6.4	1/4
11.1	7/16	7.9	5/16
12.7	1/2	9.5	3/8

Multi-cavity molds should have balanced runner systems. On multi-cavity molds with primary and secondary runners, the primary runner should carry on beyond the intersection of the secondary runner in order to provide a cold slug well for the runner flow front. Runner length, however, should be kept at a minimum (Figure 16).

**Figure 16:** Balanced runner and cavity

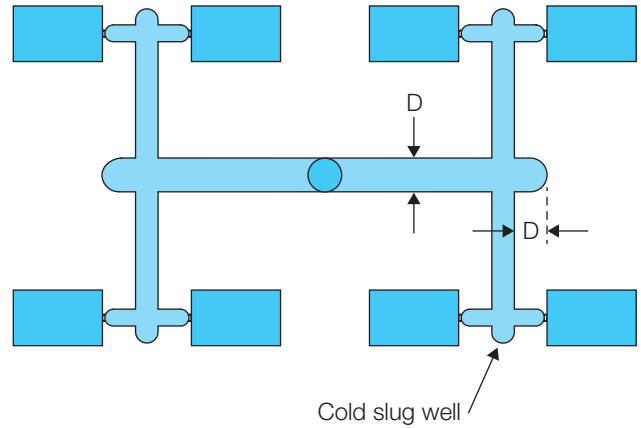

Runner length should be kept at a minimum with runner diameter optimized for the compound to be used. Suggested minimum runner diameters are listed in Table 1. The diameters listed in the table are suggested sizes starting at the gate and moving toward the sprue. The diameter should be increased 20% at each 90° runner turn. Where two secondary runners converge to form a larger secondary runner or main runner, the diameter should be increased 40%. In addition, for eight cavity or higher molds, the use of a melt flipper should be considered. For specific details about the melt flipper technology, please contact your Solvay representative or contact the manufacturer, Beaumont Runner Technologies, Inc. ([www.meltflipper.com](http://www.meltflipper.com))

**Table 1:** Minimum runner diameter, mm (inch)

	R-4 R-4-230	R-4 XT, R-4-200	BR111 R-7-120
L = 127 (5)	3.175 (0.125)	4.775 (0.188)	4.775 (0.188)
L = 254 (10)	4.775 (0.188)	6.350 (0.250)	6.350 (0.250)
L = 381 (15)	6.350 (0.250)	7.950 (0.313)	7.950 (0.313)

Generally, it is good practice with engineering thermoplastics to not use family mold layouts because of differences in filling patterns. These differences are sometimes difficult to control and may produce parts with differing physical and mechanical properties. However, if a family mold must be used, a rotating runner shut-off should be incorporated into the runner design in order to allow individual cavity molding.

## Venting

To successfully mold Ryton® PPS compounds, proper venting is essential. Poor or improper venting results in hard to fill parts and burning of the part in areas where gas is trapped. In addition, trapped gas leads to accelerated mold wear.

Venting can be accomplished with 0.0076–0.0127 mm (0.0003–0.0005 inch) deep by 6.4 mm (0.25 inch) wide channels cut on the parting line (Figure 17). Flattened ejector pins can also be used as vents. Stationary vent pins are not recommended as various substances can clog them over long part runs. Vacuum venting has been used successfully in areas where a blind pocket exists. The vacuum is turned on after the mold closes and prior to the start of the injection cycle. Vented runners are recommended.

**Figure 17:** Parting line vent detail

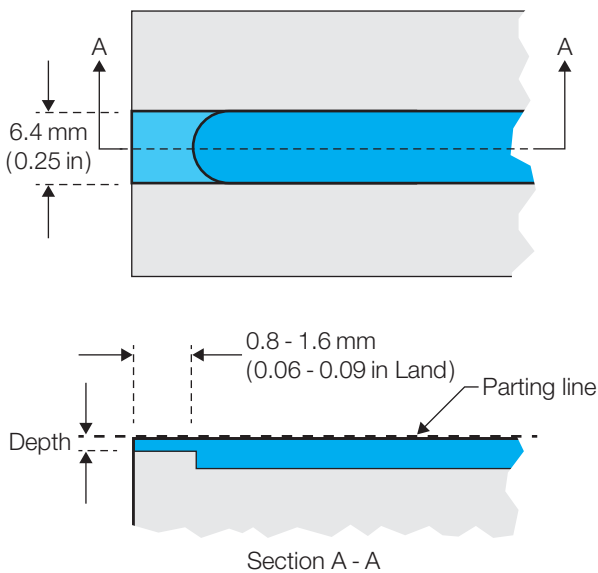

## Gate Geometries

The illustration in Figure 18 points out some of the pitfalls of less than optimal gating methods and offers design solutions.

Part distortion is caused by differential shrinkage. As the molded part shrinks, internal stresses are developed which distort the part. The greater the difference in part cross sections, the greater the chance of distortion.

To avoid distortion, the designer should strive to maintain uniformity throughout the part and minimize weld lines. Since Ryton® PPS compounds are filled compounds, they behave anisotropically. For typical Ryton® PPS compounds, this means parts will shrink about half as much in the flow direction as perpendicular to the direction of flow.

**Figure 18:** Gate geometries

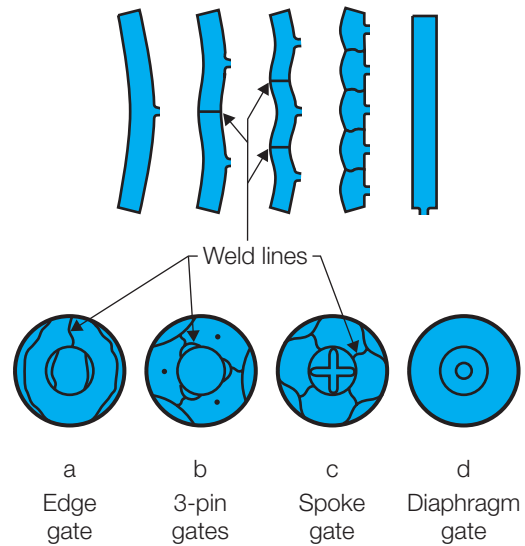

For larger parts, direct gating into the top surface using multiple gates has shown to be effective in reducing warpage.

## Gates

A variety of different gating methods is suitable for molding Ryton® PPS compounds. The graph of minimum gate diameter or thickness versus overall part volume shown in Figure 19 depicts the relative need for increasing the gate diameter or thickness as overall part volume increases. The remove quotes for round gates shown in Figure 19 may also be considered the minimum gate thickness for typical rectangular gates having a width of two times the gate thickness. A good guideline for larger parts is for the gate diameter or thickness to be about 60% to 75% of the maximum wall thickness of the part. Success has been shown with center, sprue, tab, flash, round, disk, submarine, and spoke gates. The placement of the gate is essential in determining the potential strength and dimensional stability of the part. Small parts can usually be gated in a single location to prevent weld lines. If the part cannot be molded without weld line(s), the weld line(s) should be placed in the thickest section of the part or in areas where there is minimal stress.

**Figure 19:** Minimum Gate Diameter

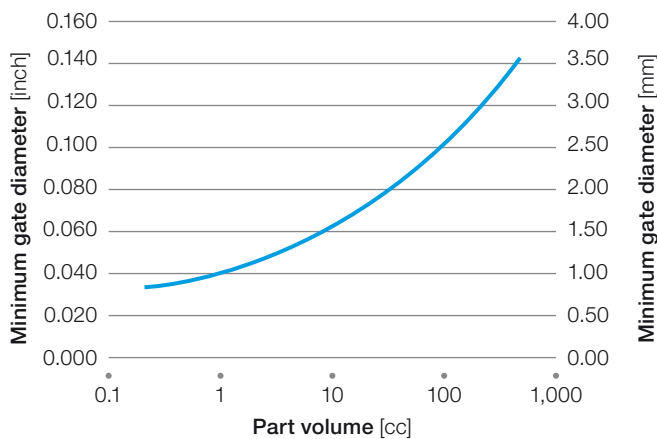

The following list represents the majority of gating choices available. Where it is applicable, the gate land length should be kept as short as possible or 0.030 in maximum.

### Center/sprue gate

Efficient and works well on parts where concentricity is important or parts with dome shapes (Figure 20).

### Pin gate

Used much like a sprue gate, this gate can be used with multi-cavity tooling and provides automatic separations of part from runner (Figure 21).

### Fan gate

Good for uniform polymer flow front into a part similar to a flash gate (Figure 22).

### Diaphragm (disk) gate

Ideal for producing highly concentric cylindrical parts without weld lines (Figure 23).

### Spoke gate

Can be used in parts which are too large for a diaphragm gate. Odd number of spokes should be used so that gates are not opposite one another. In addition, gates should be positioned such that weld lines form in the areas of thickest cross section (Figure 24).

### Flash gate

Good for parts with large flat surfaces requiring minimum warpage (Figure 25).

### Edge gate

Most commonly used; allows high degree of fiber orientation and is generally seen on multi-cavity molds requiring moderate precision in tolerances (Figure 26).

### Tunnel (submarine) gate

Submarine gates have been used successfully with Ryton® PPS compounds; however, special consideration must be given to the design. The tunnel included angle should be 30–35° and the center line of the tunnel should be 25–30° from a line drawn perpendicular to the mold parting line. Figure 27 presents a recommended submarine gate design. The tunnel must be well polished with no undercuts.

**Figure 20:** Sprue gate

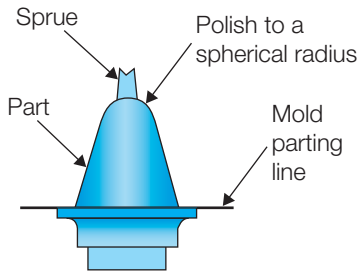

**Figure 21:** Pin gate

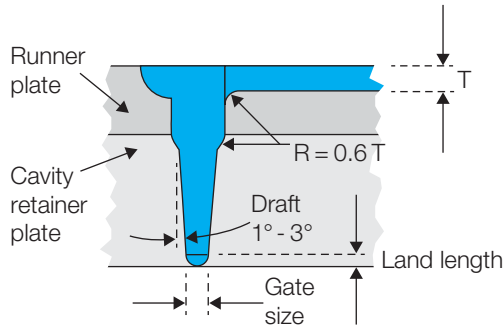

**Figure 22:** Fan gate

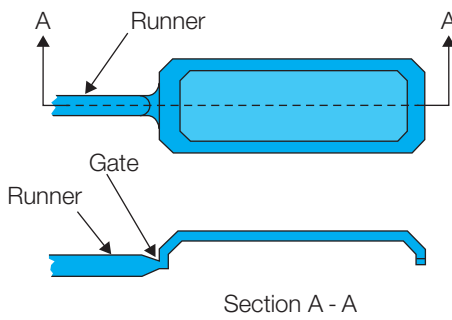

**Figure 23:** Diaphragm gate

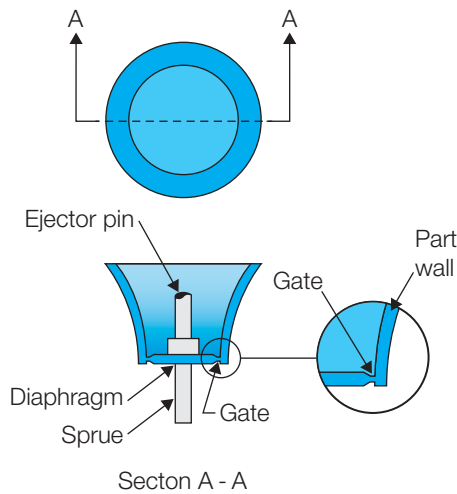

**Figure 24:** Spoke gate

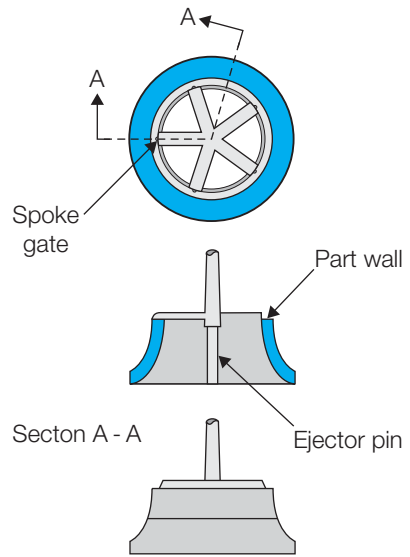

**Figure 25:** Flash gate

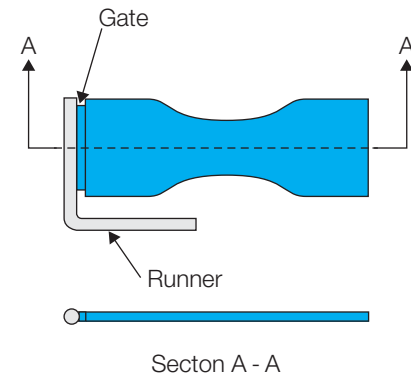

**Figure 26:** Edge gate

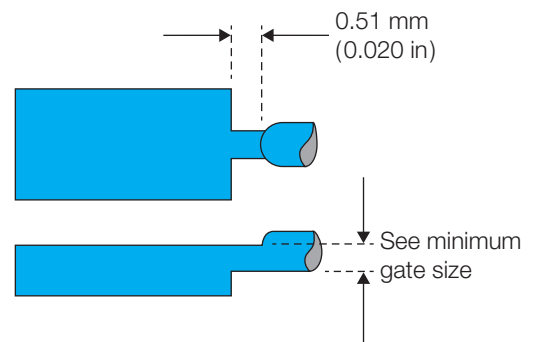

**Figure 27:** Tunnel gate

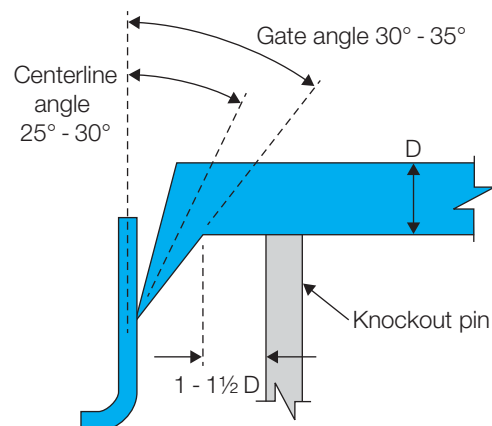

## Coring

Thick part sections should be cored to provide uniform wall thickness. This design practice will avoid sink marks and voids, reduce stress and cycle time, and offer material savings. Cores that extend into the cavity will be subject to high pressure; therefore, these cores should generally have a minimum diameter of  $D = 1.27 \text{ mm}$  (0.05 inch) and should not extend more than  $2D$  unless they pass entirely through the cavity (Figure 28).

**Figure 28:** Coring problems and solutions

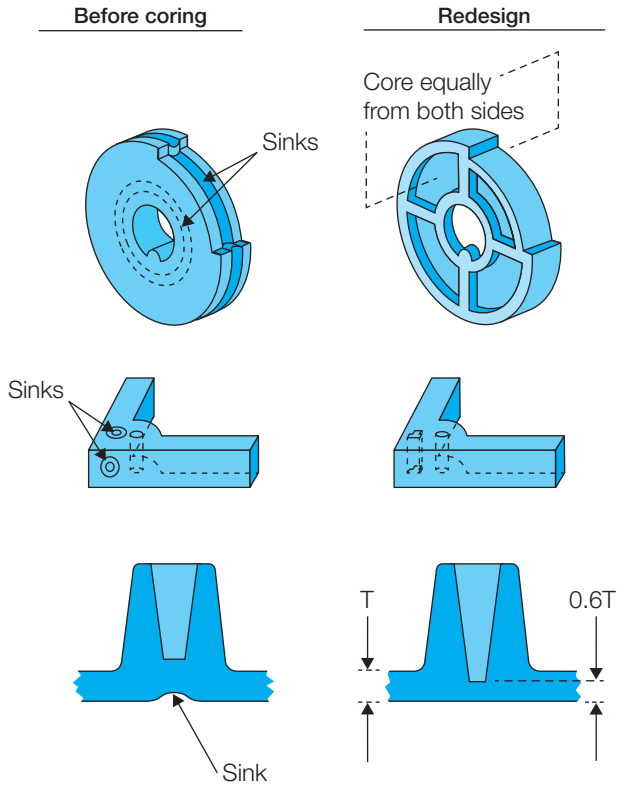

## Draft

Ryton® PPS compounds flex very little during ejection; therefore, the part design should provide sufficient draft to eject the part without flexure. Short cores and shallow cavities of 4.76 mm (3/16 inch) or less should have at least  $1/4^\circ$  draft per side. As cavity depth and core length increases to one or two inches, draft angle should increase up to  $2^\circ$  per side. Polishing the core and cavity will improve release so specify a surface finish of 0.0001 mm (4 microinch) or better. Polish marks should parallel the direction of part ejection. This is typically referred to as draw polishing.

# Assembly Methods

Most products incorporate several functions that require different levels of performance or dimensional precision. In many cases, Ryton® PPS compounds can meet all these requirements, allowing the designer to combine these functions into a single molding. When part geometry or functional needs necessitate more than one molding or material, the components should be designed to minimize the cost and complexity of assembly procedures.

Ryton® PPS parts may be assembled using a variety of techniques, each requiring certain design considerations. Procedural details are presented in other Ryton® PPS literature.

## Ultrasonic Welding

Ryton® PPS compounds are relatively easy to weld together. Joint design is, however, critical to the finished part strength. A shear joint is the best overall, although the step joint has been used successfully with Ryton® R-4. The shear joint will generally be six times stronger than the step joint. There are many types of joint designs. Typical designs for shear and step joints are shown in Figures 29 and 30.

When welding shear joints, use high power with a high amplitude booster, low pressure, and slow horn speed. When welding the parts, caution should be used since too high of an amplitude and/or too long of an application time could destroy the part (Figure 29).

Shear joints are usually not recommended for parts with a maximum dimension of 89 mm (3.5 inch) or greater, sharp 90° turns, or irregular shapes, due to the difficulty of holding the required molding tolerances. Ryton® PPS may extend these limits, however, since it can hold tight molding tolerances.

Some of the more common joint design mistakes to avoid are:

1. Joints that are too tight or too close together which prevents adequate vibration
2. Section transmitting the ultrasonics is too thin as it may crack under the high amplitude level
3. Too large of a step, requiring a high instant power that may destroy the part
4. Assembly in which the highest part does not vibrate
5. Energy director design that prevents a homogenous weld

**Figure 29:** Shear joint for ultrasonic welding

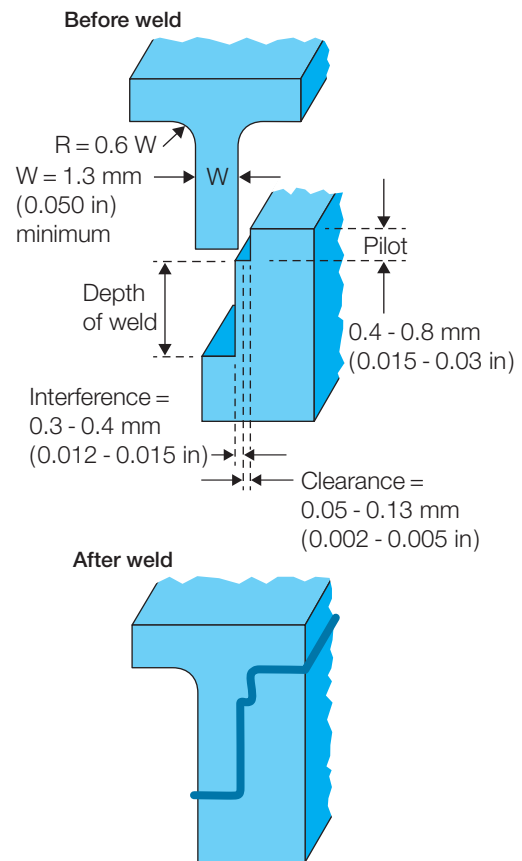

**Figure 30:** Step joint for ultrasonic welding

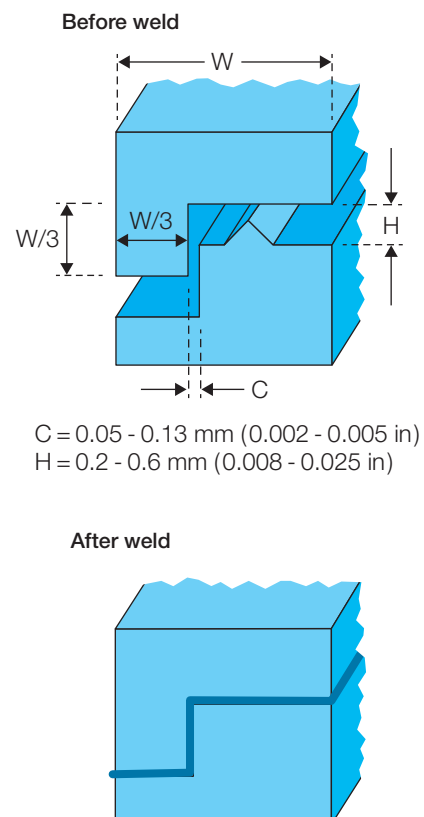



## Ultrasonic Staking

Ultrasonic staking is an assembly method that uses the controlled melting and reforming of a plastic stud or boss to capture or lock another component of the assembly. The plastic stud protrudes through a hole in the component, then the high frequency vibrations of the ultrasonic horn are imparted to the top of the stud. The stud melts and fills the volume of the horn cavity to produce a head, locking the component in place. The progressive melting of plastic under continuous but generally light pressure forms the head. Ultrasonic staking causes some reduction in tensile strength of the reformed stud.

The advantages of ultrasonic staking include short cycle time, tight assemblies with virtually no tendency for recovery, ability to perform multiple stakes with one horn, repeatability and control over the process, design simplicity, and the elimination of consumables such as screws.

There are two head-forms that will satisfy the requirements of a majority of applications (Figure 31). The first, generally considered standard, produces a head having twice the diameter of the original stud, with a height 1/2 the stud diameter. The second, referred to as a low-profile, has a head diameter 1 – 1/2 times the stud diameter, with a head height 1/4 the size of the head diameter.

**Figure 31:** Ultrasonic staking methods

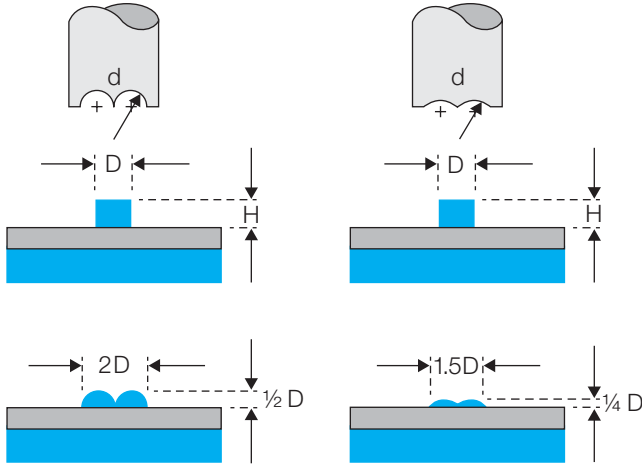

## Heat Staking

Heat staking is very similar to ultrasonic staking and has many of the same advantages plus greater strength.

Testing has demonstrated that amorphous parts (cold molded) stake more easily and exhibit more strength than crystalline (hot molded) parts. The rate of heat transfer is controlled by adjusting the interdependent variables of the tip temperature and downward pressure. Too much pressure and/or too low of a temperature will crack the post before melt-deformation can occur.

The optimal process conditions for a typical 3.18 mm (1/8 inch) diameter post might be, for an amorphous part, a tip temperature of 310 °C (590 °F). For a crystalline part, use a tip temperature of 327 °C (620 °F). The downward force is typically 68 kg (150 lbs.) applied for 40 seconds. Since the staked area will be amorphous after the melt/deformation, the assembly should be annealed at 204 °C (400 °F) for 2 hours if the application requires a fully crystalline part.

The heat staking tip is designed in the same manner as the horn head for an ultrasonic staking unit. However, since all glass reinforced compounds can be abrasive, we recommend that the staking tip be made of a hardened steel with a Rockwell C rating of 60 or greater.

## Snap Fit

The most convenient method of assembling plastic parts is the snap fit. The savings in assembly costs more than offset the increase in tooling costs required by this technique. Studies have shown that the high strength and rigidity of Ryton® PPS compounds provide good holding strength with a minimum of flex and interference. Figure 32 details the guidelines for the design of snap fit members for different Ryton® PPS compounds. Typically, Ryton® PPS snap fit applications involve only one time assembly.

**Figure 32:** Snap fit design parameters

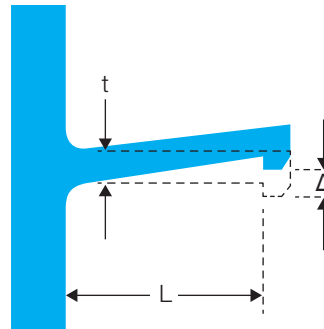

Calculate maximum deflection by:

$$\Delta = \frac{\epsilon L^2}{3C}$$

where:

$\Delta$  = Deflection at break\*

L = Length

C = t/2

t = Thickness

$\epsilon$  = 0.018 for R-4XT, R-4-200

0.014 for R-4, R-4-230

0.010 for R-7, R-7-120, BR111

\* Use 75 % for one time assembly

Use 50 % for multiple assemblies

## Rivet Assembly

Ryton® PPS can be successfully assembled using semi-tubular style rivets.

The definition of a semi-tubular rivet is a rivet whose mean hole depth, measured on the wall, does not exceed 112 % of its mean body diameter. This design will put less stress on the molded parts, especially if the distance between the hole and the underside of the head is the same as the combined material thickness. In order to ensure that minimum stress is placed on the molded parts during riveting operations, it is essential that the rivet setter be adjusted to exert the minimum impact required to clinch the rivet. Even more successful are the (Tommel) rivet setting machines that round over the metal on the bottom of the rivet. This places even less stress on the part (Figure 33).

**Figure 33:** Example rivets

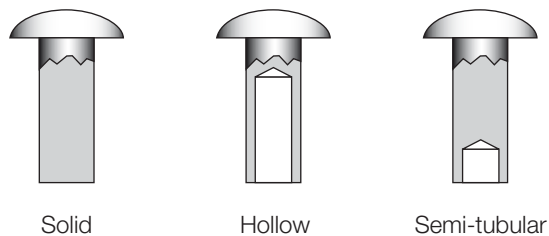

## Adhesives

Adhesive bonding is a versatile method of joining like or dissimilar materials. Holes, rivets, clamps, and screws have a tendency to cause stress points in concentrated areas. Adhesives tend to distribute the load over the entire area, thus virtually eliminating localized stress areas. There are many adhesives that will bond Ryton® PPS compounds, provided the surface is properly prepared to allow the adhesive to wet the surface. The adhesive should be selected to best meet the need for the application in which the product will ultimately be used.

In each adhesive application, the following criteria must be considered:

1. Characteristics of the materials to be joined
2. Surface preparation
3. Joint design
4. Adhesive selection and handling
5. Application
6. Cure of the adhesive/adhered couple
7. Ultimate strength and environmental performance of the “adhesively joined” fabricated part or structure.

Surface preparation and adhesive selection is discussed in our technical bulletin entitled, “Bonding Adhesives and Paints to Ryton® PPS.”

## Tapped Threads for Bolts

It is often desirable to assemble plastic components to each other or to different materials using bolts. In most applications where repeated assembly and disassembly is not required, Ryton® PPS moldings with tapped threads work very well.

To characterize the bolt holding strength of Ryton® PPS compounds, holes were drilled in injection molded 15.9mm (0.625 inch) thick Ryton® PPS R-4 and R-10 7006A slabs. Three hole sizes were tapped for a variety of common threads, ranging from 4-40 to 1/4-20 bolts. The three hole sizes chosen were, one hole size smaller, one hole size larger, and the recommended hole size for steel threads, as shown in the “Machinery’s Handbook” for each bolt. The bolts were then screwed into the hole to three depths, four bolt diameters (except the 1/4-20), two bolt diameters, and three turns. Samples were then pulled in an Instron to measure the force required either to pull the bolt from the hole, or to break the bolt.

The data in Table II demonstrates that tapped holes in Ryton® PPS glass mineral filled compounds have excellent bolt holding power. Bolts screwed in to a depth of four bolt diameters equaled or exceeded the tensile strength of brass and mild steel bolts. Bolts screwed in three turns and those at two bolt diameters also had excellent strength.

**Table 2:** Bolt holding strength in Ryton® PPS glass mineral filled compounds

<b>Bolt Size</b>	<b>Drill Size</b> [mm (inch)]	<b>Bolt Depth</b>	<b>Pull Out Strength</b> [N (lbf)]
4-40, Mild steel 2.84 (0.112)	No. 43 2.26 (0.089)	3 Turns	818 (184)
		5.69 (0.224)	413 (1837)
		11.38 (0.448)	1744 (3921)
6-32, Brass 3.51 (0.138)	No. 36 2.69 (0.106)	3 Turns	1085 (244)
		7.01 (0.276)	2544 (5721)
		13.26 (0.522)	2664 (5991)
8-32, Brass 4.17 (0.164)	No. 29 3.45 (0.136)	3 Turns	1050 (236)
		8.33 (0.328)	3385 (7611)
		15.88 (0.625)	3385 (7611)
10-24, Mild steel 4.83 (0.190)	No. 25 3.78 (0.149)	3 Turns	1628 (366)
		9.65 (0.380)	5040 (11332)
		15.88 (0.625)	6263 (14081)
10-32, Brass 4.83 (0.190)	No. 21 4.04 (0.159)	3 Turns	1219 (274)
		8.08 (0.318)	4092 (9202)
		15.88 (0.625)	6094 (13701)
1/4-20, Mild steel 6.35 (0.250)	No. 7 5.33 (0.210)	3 Turns	2491 (560)
		13.97 (0.550)	10942 (24602)
		15.88 (0.625)	11640 (26171)

1= Bolts Broke, 2= Stripped Threads

### Self-Tapping Screws

The excellent creep resistance of Ryton® PPS makes it well suited for assembly with self-tapping screws. Due to the hardness of Ryton® PPS compounds, thread cutting types, rather than thread forming types, perform best. The hole size recommended by the “Machinery’s Handbook” for phenolformaldehyde thermosets should be used.

Tables 3, 4 and 5 show the holding power and torque retention of self-tapping screws in Ryton® PPS 40 % glass filled and 65 % glass/mineral filled compounds. This data indicates that Ryton® PPS is an excellent choice for screw assembly techniques.

**Table 3:** Self-tapping (thread cutting) screw holding power in Ryton® PPS 40 % glass filled compound

<b>Screw Type and Size Mild Steel</b>	<b>Thread Engagement</b> [mm (inch)]	<b>Driving Torque</b> [Nm (inch · lbf)]	<b>Undriving Torque</b> [Nm (inch · lbf)]	<b>Stripping Torque</b> [Nm (inch · lbf)]	<b>Avg. Holding Load Tensile</b> [N (lbf)]	<b>Suggested Drill Size</b> [mm (inch)]
Type F						
#4-40	4.76 (3/16)	0.2 (2)	0.1 (1)	1.0 (9)	729 (164)	#40 2.49 (0.0980)
4-40	7.94 (5/16)	0.5 (4)	0.2 (2)	1.7 (15)	2122 (477)	40 2.49 (0.0980)
6-32	6.35 (1/4)	1.0 (9)	0.7 (6)	2.1 (19)	1597 (359)	32 2.95 (0.1160)
6-32	7.94 (5/16)	1.2 (11)	1.0 (9)	3.7 (33)	2420 (544)	32 2.95 (0.1160)
8-32	7.94 (5/16)	1.1 (10)	1.1 (10)	>5.6 (>50)	2722 (612)	27 3.66 (0.1440)
8-32	12.7 (1/2)	2.4 (21)	2.4 (21)	>5.6 (>50)	6049 (1360)	27 3.66 (0.1440)
10-24	7.94 (5/16)	2.0 (18)	1.7 (15)	5.1 (45)	2188 (492)	20 4.09 (0.1610)
10-24	12.7 (1/2)	2.7 (24)	2.7 (24)	>5.6 (>50)	4906 (1103)	20 4.09 (0.1610)
10-32	7.94 (5/16)	3.2 (28)	3.2 (28)	>5.6 (>50)	3314 (745)	20 4.09 (0.1610)
10-32	12.7 (1/2)	5.6 (50)	5.6 (50)	>5.6 (>50)	5035 (1132)	20 4.09 (0.1610)

**Table 4:** Self-tapping screw holding power in Ryton® PPS 65 % glass filled compound

Screw Size [mm (inch)]	Drill Size [mm (inch)]	Thread Engagement [mm (inch)]	Driving Torque [Nm (inch·lbf)]	Undriving Torque [Nm (inch·lbf)]	Stripping Torque [Nm (inch·lbf)]	Pull Out Strength [N (lbf)]
4-40, 2.84 (0.112)	No. 40 2.49 (0.0980)	4.76 (3/16) 7.94 (5/16)	0.2 (2) 0.5 (4)	0.1 (1) 0.3 (3)	0.1 (9) 1.6 (14)	983 (221 <sup>2</sup> ) 1993 (448)
6-32 3.51 (0.138)	No. 32 2.95 (0.1160)	6.35 (1/4) 7.94 (5/16)	0.9 (8) 1.0 (9)	0.7 (6) 0.8 (7)	2.0 (18) 2.7 (24)	1672 (376 <sup>2</sup> ) 2638 (593)
8-32 4.17 (0.164)	No. 27 3.66 (0.1440)	7.94 (5/16) 12.7 (1/2)	1.1 (10) 1.8 (16)	0.9 (8) 1.7 (15)	>5.6 <sup>1</sup> (>50) >5.6 <sup>1</sup> (>50)	2464 (554 <sup>2</sup> ) 5618 (1263)
10-24 4.83 (0.190)	No. 20 4.09 (0.1610)	7.94 (5/16) 12.7 (1/2)	1.8 (16) 3.1 (35)	1.2 (11) 2.7 (24)	>5.6 <sup>1</sup> (>50) >5.6 <sup>1</sup> (>50)	2233 (502 <sup>2</sup> ) 5769 (1297)
10-32 4.83 (0.190)	No. 20 4.09 (0.1610)	7.94 (5/16) 12.7 (1/2)	3.2 (28) >5.6 (>50)	2.8 (25) 4.6 (41)	>5.6 <sup>1</sup> (>50) >5.6 <sup>1</sup> (>50)	3389 (762 <sup>2</sup> ) 5983 (1345)

<sup>1</sup> Accurate readings could not be obtained above 5.6Nm (50 inch·lbf) of torque.

<sup>2</sup> Failures resulted from brittle fracture of Ryton® PPS.

**Table 5:** Torque retention of self-tapping screws in Ryton® PPS 40 % glass-filled compound

Application Torque [Nm (inch·oz)]	Unscrewing Torque after 24 h at Room Temp., [Nm (inch·oz)]	Unscrewing Torque after 24 h at 71 °C (160 °F), [Nm (inch·oz)]
0.092 (13)	0.087 (12.3)	0.083 (11.7)
0.113 (16)	0.101 (14.3)	0.085 (12.0)
0.141 (20)	0.125 (17.7)	0.118 (16.7)

#### Screw Data

- Screw length: 4.98 mm (0.196 inch)
- Screw diameter: 1.85 mm (0.073 inch)
- Drilled hole size: 1.50 mm (0.059 inch)
- Height of head: 1.80 mm (0.071 inch)
- Head diameter: 3.00 mm (0.118 inch)
- Contact area of head: 4.50 mm<sup>2</sup> (0.007 inch<sup>2</sup>)

## Ultrasonic Inserts

Like other thermoplastics, Ryton® PPS can be conveniently assembled using ultrasonic inserts. Table 6 shows how a 15.9mm (0.625 inch) Ryton® PPS, 65 % glass/mineral filled compound slab was used to develop pull data on three common sizes of inserts. Inserts of these types are recommended when repeated disassembly is required, and good pull-out strength is desirable. Figure 34 shows design recommendations for other common inserts.

The tapered hole is specified for the following reasons:

1. Positioning of the insert is faster, more accurate and ensures proper alignment every time
2. Places the insert in a “partially installed” position in the hole, permitting more rapid installation because the volume of plastic which must be displaced is decreased
3. Provides the best release of the plastic part from the mold

**Figure 34:** Design recommendations for ultrasonic inserts

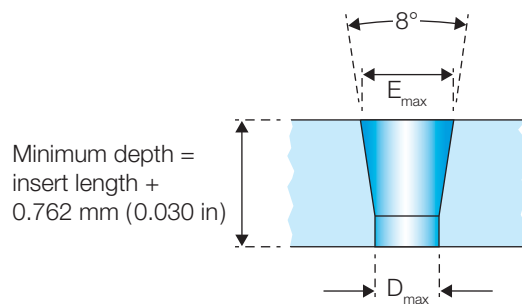

**Table 6:** Specifications for ultrasonic inserts

Size	Insert Length	D Max.	E Max.
No. 0 & No. 2	0.115	0.121	0.126
	0.188	0.110	0.126
No. 4	0.135	0.156	0.162
	0.219	0.144	0.162
No. 6	0.150	0.202	0.209
	0.250	0.188	0.209
No. 8	0.185	0.229	0.237
	0.312	0.211	0.237
No. 10	0.225	0.270	0.280
	0.375	0.249	0.280
1/4 inch	0.300	0.352	0.366
	0.500	0.324	0.366
5/16 inch	0.335	0.434	0.451
	0.562	0.404	0.451
3/8 inch	0.375	0.526	0.543
	0.625	0.491	0.543

(All dimensions in inches)

## Molded-In Threads

Because of the excellent processability of Ryton® PPS, molded-in threads can be designed into most parts. This will eliminate the need for expensive secondary machining operations. Molding in the threads should also provide superior performance, as compared to machined threads, due to the normal skin effect on injection molded parts. Table 7 has the pull-out values for molded-in threads.

**Table 7:** Holding power of various fastening methods in Ryton® PPS 65 % glass mineral filled compounds

Fastening Method	Fastener Type	Thread Size [mm (inch)]	Drill Size [mm (inch)]	Engagement [mm (inch)]	Pull Out Strength [N (lbf)]
Ultrasonic insert	Dodge® Ultrsert II*	6-32	4.78 (0.188)	6.35 (0.250)	1704 (383)
		3.51 (0.138)			
Ultrasonic insert	Dodge® Ultrsert II*	10-32	6.32 (0.249)	9.53 (0.375)	3492 (785)
		4.09 (0.161)			
Molded threads		1/4-20		12.7 (0.500)	7264 (1633)
Molded inserts	Yardley® (Brass) standardized	1/4-20		12.7 (0.500)	13731 (3087)
		6.35 (0.250)			

## Molded-In Inserts

Because of the excellent processability of Ryton® PPS, molded-in inserts can be designed into many parts. Molded-in inserts may be used when repeated assembly and disassembly of parts is required. Since Ryton® PPS easily molds around inserts, excellent pull-out strengths should be expected. Inserts are recommended when an appreciable amount of preload is desired. The insert should be designed such that the load is carried through the metal insert and not the plastic. Flanged type inserts work well for highly loaded applications.

## Interference Fit

The strength and modulus of Ryton® PPS compounds makes them suitable for retention of interference fit components; however, molded-in inserts are generally preferred especially for larger components such as hubs or bearings. To prevent cracking, the degree of interference should typically not induce more than about 0.5% hoop strain. Tests have shown that increasing depth of insertion (or increasing the area of surface contact) can be more effective at improving pull out strength than increasing interference.

## Machining

Because of its exceptional mechanical properties, Ryton® PPS can be readily machined with conventional metal working tools. A high degree of precision can be obtained with Ryton® PPS while using moderate cutting speeds and fast feed rates. It is recommended that carbide tipped tools be used for machining all Ryton® PPS compounds.

In general, the best surface speed will be in the range of 1.5 to 3.5 m/s (300 to 700 SFM) for turning operations, 0.5 to 1.0 m/s (100 to 200 SFM) for milling operations, and 1.0 to 1.5 m/s (200 to 300 SFM) for drilling and reaming.

The rate of travel should be relatively fast. A slow feed results in excess abrasion by the tool and will tend to give poor surface appearance. If a coolant is desired, ethylene glycol (antifreeze) works well.

Although fairly deep cuts of up to 3.17 mm (1/8 inch) can be made, finish cuts should take off no more than 0.127 mm (0.005 inch) of material.

## Computer Aided Engineering (CAE)

Our Computer Aided Engineering services include a full complement of analysis programs prepared to assist at any stage of the development cycle. From design to testing, you can be assured that your product is being evaluated with state-of-the-art programming by material and processing experts.

- Computer Aided Design
- Material selection
- Flow analysis
- Shrink evaluation
- Molding optimization
- Finite Element Analysis

## Conclusion

These design guidelines are intended to help designers maximize the versatility of Ryton® PPS engineering thermoplastics in their products. Our suggestions are the result of direct experimentation and our Technical Service staff's experiences in helping customers. For more detailed information, contact Solvay Specialty Polymers.





## Specialty Polymers

### Worldwide Headquarters

**SpecialtyPolymers.EMEA@solvay.com**

Viale Lombardia, 20  
20021 Bollate (MI), Italy

### Americas Headquarters

**SpecialtyPolymers.Americas@solvay.com**

4500 McGinnis Ferry Road  
Alpharetta, GA 30005, USA

### Asia Headquarters

**SpecialtyPolymers.Asia@solvay.com**

No.3966 Jindu Road  
Shanghai, China 201108

[www.solvay.com](http://www.solvay.com)

Safety Data Sheets (SDS) are available by emailing us or contacting your sales representative. Always consult the appropriate SDS before using any of our products.

Neither Solvay Specialty Polymers nor any of its affiliates makes any warranty, express or implied, including merchantability or fitness for use, or accepts any liability in connection with this product, related information or its use. Some applications of which Solvay's products may be proposed to be used are regulated or restricted by applicable laws and regulations or by national or international standards and in some cases by Solvay's recommendation, including applications of food/feed, water treatment, medical, pharmaceuticals, and personal care. Only products designated as part of the Solviva® family of biomaterials may be considered as candidates for use in implantable medical devices. The user alone must finally determine suitability of any information or products for any contemplated use in compliance with applicable law, the manner of use and whether any patents are infringed. The information and the products are for use by technically skilled persons at their own discretion and risk and does not relate to the use of this product in combination with any other substance or any other process. This is not a license under any patent or other proprietary right.

All trademarks and registered trademarks are property of the companies that comprise the Solvay Group or their respective owners.  
© 2016, Solvay Specialty Polymers. All rights reserved. D 06/2012 | R 03/2016 | Version 2.2 Brochure Design by [www.ahlersheinel.com](http://www.ahlersheinel.com)